

# Orbitrap Exploris MX Mass Detector

## Perfect fit. Fit for purpose.

### Introduction

The Thermo Scientific™ Orbitrap Exploris™ MX mass detector is based on proven hardware and instrument control software designs of the next-generation Thermo Scientific™ Orbitrap™ platform.<sup>1</sup>

The Orbitrap Exploris MX mass detector provides operational simplicity, compliance readiness, reliability and robustness needed for BioPharma late stage development, manufacturing and QC.

For monitoring biopharmaceutical product attributes during product development, process development, and manufacturing, the system offers superior data quality and therefore provides high confidence in the results from peptide level through intact protein analysis up to the molecular weight of monoclonal antibodies, analyzed under denaturing and under native conditions.

### Benefits

- Exceptional quantitative and qualitative Full-MS<sup>1</sup> performance with the fast-scanning high-field Orbitrap mass analyzer
- Next-generation software with intuitive tuning, single-click calibration, drag-and-drop method setup, and pre-defined method templates
- Rapid “set and forget” calibration procedures provide consistent mass stability for at least four weeks at prescribed conditions
- Extended mass transmission and detection up to  $m/z$  8,000 with the Thermo Scientific™ BioPharma option
- Part of the end-to-end Thermo Scientific MAM 2.0 solution to comprehensive characterization and monitoring of biotherapeutics from development to manufacturing



### Scan function

Full MS scan type is available.

### Hardware features

#### Ion source

##### *Thermo Scientific™ OptaMax™ NG ion source*

- Ultimate sensitivity with an efficient, heated electrospray ionization (HESI-II) sprayer to deliver maximum performance with minimal optimization required
- Optimal mass and system calibration with non-heated low-flow calibrant sprayer
- Supporting flow rates from 1–1000  $\mu\text{L}/\text{min}$ :
  - low flow needle 1–10  $\mu\text{L}/\text{min}$
  - high flow needle 10–1000  $\mu\text{L}/\text{min}$
- Enhanced ruggedness, efficient desolvation and reduced chemical noise with applying sweep, sheath and auxiliary gases

## Ion optics

The atmospheric pressure ionization (API) interface consists of:

### Round bore transfer tube

- Removable, heated ion transfer tube
- Vent-free maintenance

### Stacked-ring ion guide (S-lens)

Stacked-ring radio frequency (RF) ion guide captures and efficiently focuses the ions into a tight ion beam. Large variable spacing between electrodes allows for better pumping efficiency and improved ruggedness.

### Advanced active beam guide (AABG)

- Reduces noise by preventing neutrals and high-velocity clusters from entering the downstream ion optics using a double bent design geometry
- Axial field along the length of the rods improves ion transfer robustness

## Thermo Scientific™ EASY-IC™ ion source

- Provides <1 ppm RMS mass accuracy under defined conditions with minimum effort for at least five days
- Generates optional internal reference ions for real-time mass correction and mass recalibration in both positive and negative ionization mode

## Ion-routing multipole (IRM)

Robust ion trapping for MS scans.

## Automatic gain control (AGC)

Reliable AGC measurements for controlled injection of the number of ions is ensured by the novel Independent Charge Detector.

## Thermo Scientific™ Orbitrap™ mass analyzer

- High-field Orbitrap mass analyzer with 4 kV central electrode voltage
- Low noise detection pre-amplifier

## Vacuum system

- A compact single six-stage turbomolecular pump design regulates the vacuum in six stages for the aluminum high-vacuum analyzer chambers
- Advanced vacuum technology reduces pressure in the ultra-high vacuum regions, enhancing transmission of ions to the Orbitrap mass analyzer

Performance specifications	
Mass Range	Standard mass range $m/z$ 40–3,000, up to $m/z$ 8,000 with BioPharma option
Orbitrap Mass Analyzer Resolution	Up to 180,000 at $m/z$ 200
Scan Rate*	Up to 22 Hz at resolution setting of 15,000
Mass Accuracy*	External calibration achieves <3 ppm RMS drift over 24 hours; 1-point calibration achieves <3 ppm RMS drift over at least 4 weeks; Internal lock mass calibration achieves <1 ppm RMS drift over 24 hours; EASY-IC achieves <1 ppm RMS drift for at least 5 days
Dynamic Range	>5,000 within a single Orbitrap mass analyzer spectrum
Polarity Switching	One Full Scan cycle** <700 ms corresponding to >1.4 Hz
Analog Inputs	Channel 1 analog input ( $\pm 10$ V), Channel 2 analog input ( $\pm 10$ V)

\* Under defined conditions

\*\* One cycle consists of acquiring one Full scan in positive mode and one Full scan in negative mode at a resolution setting of 60,000

## Data acquisition system

### Data System

- High-performance PC with Intel® microprocessor
- High-resolution LED color monitor
- Microsoft® Windows® 10 Enterprise (Long Term Service version) operating system
- High-speed real-time data acquisition and instrument control
- Automatic calibration of all ion transfer and mass analysis parameters via instrument control software

### Orbitrap Exploris instrument control software

- Tune application for mass calibration, system calibration, system checks, diagnostics, and manual data acquisition
- Method Editor with a comprehensive application-specific template library, method setup supported by tooltips, and a drag-and-drop user interface to facilitate method development
- Sets optimal default instrument parameters
- Application Modes
  - Sets optimal default instrument parameters and manages application-specific system templates for easy method development and execution. Available modes are:
    - Small molecule
    - Peptide
    - Intact Protein (included with BioPharma option)

### Thermo Scientific™ Chromeleon™ Chromatography Data System (CDS)

- Compliant instrument tuning and control, with secure log-on, audit trails covering all actions, and full version control, are provided as standard
- The first CDS that combines all separation and detection techniques, including mass spectrometry, into a single compliance-ready enterprise (client/server) environment
- Full 21 CFR Part 11 and GxP compliance-readiness for data acquisition, processing, and reporting

## Options

### BioPharma option

- Analysis of large molecules including, but not limited to, intact proteins and large complexes under denaturing or native conditions
- Enables mass transmission and detection up to  $m/z$  8,000
- With Application Mode 'Intact Protein', pressure regimes can be selected to achieve optimal performance under native and denaturing conditions

### Thermo Scientific™ BioPharma Finder™ software

Provides data analysis workflow for complete protein characterization, including intact protein mass analysis, top-and middle-down analysis, peptide mapping, oligonucleotide or multi-attribute method (MAM) workflows.

### Thermo Scientific™ MAM 2.0 workflow

The Thermo Scientific solution encompasses a chromatography and mass spectrometry ecosystem that enables seamless deployment of MAM from characterization to QC in a secure and compliant environment.

### Thermo Scientific™ EASY-Spray™ NG ion source

- Maximum nano-electrospray performance with minimum adjustment required

## Installation requirements

### Power

- 2×208–240 Vac single phase, 15 A, 50/60 Hz, with earth ground for instrument and source vacuum pump
- 208–240 Vac single phase, 15 A, 50/60 Hz, with earth ground for the data system

### Gas

- Source gas: high-purity nitrogen gas supply (>99% pure at 600 ± 50 kPa [6.0 ± 0.5 bar, 87 ± 7 psi])
- A pre-regulator might be required to keep the source gas pressure stable within the required limits
- C-Trap bath gas: ultra-high-purity nitrogen
- EASY-IC: ultra-high-purity nitrogen (UHP > 99.999% pure<sup>†</sup>) at 600 ± 50 kPa [6.0 ± 0.5 bar]

<sup>†</sup> with less than one ppm each water and oxygen

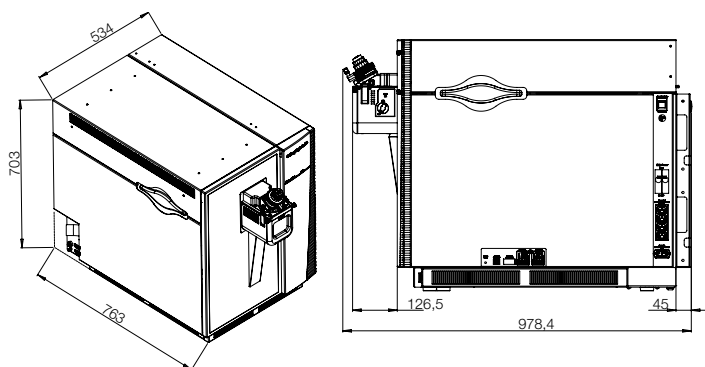

### Dimensions (w, d, h)

- 534 x 763 x 703 mm (21 x 30 x 27.7 in)

### Weight

- 120 kg (265 lb) without data system, vacuum rough pumps, and optional items

### Environment

- System averages 3440 W (11,730 Btu/h) output when considering air conditioning needs
- Operating environment must be 18–27 °C (64–81 °F). Relative humidity must be 20–80% with no condensation
- Designed for indoor use at an altitude of up to 3,000 m (10,000 ft) above sea level

### Reference

1. Thermo Scientific™ Orbitrap™ Tribrid™ mass spectrometers, Thermo Scientific™ TSQ Altis™ triple quadrupole mass spectrometer, Thermo Scientific™ TSQ Quantis™ triple quadrupole mass spectrometer, Thermo Scientific™ TSQ Fortis™ triple quadrupole mass spectrometer, and Thermo Scientific™ Orbitrap Exploris™ mass spectrometers

Learn more at [thermofisher.com/OrbitrapExplorisMX](https://thermofisher.com/OrbitrapExplorisMX)